

PSE10917

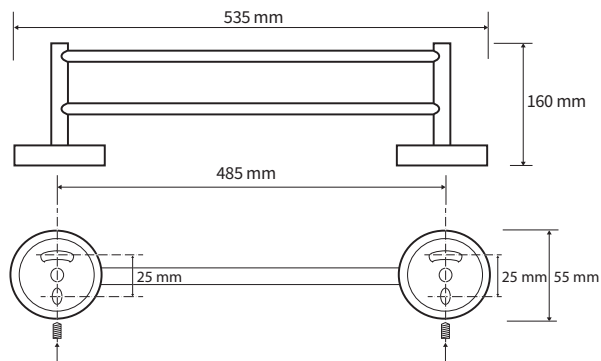

FR Spécifications techniques

Porte-serviette double

Caractéristiques

Matière : laiton

Finition : noir

Dimensions : L535 x P160mm

Fixation

Platine et vis pointeau

Visserie et chevilles fournies



Tous coloris

UK Technical specifications

Double towel rail

Features

Material: brass

Finish : black

Dimensions : W535 x D160mm

Fixings

Support plate and grub screws

Screws and wallplugs included



Any colour